

# ROTAMAT® Mini Complete Plant MiniCop



## Compact Screen and Grit Trap

- For flows of up to 115,000 GPD
- Small footprint and height
- Easy operation and maintenance
- Made of stainless steel, pickled in an acid bath



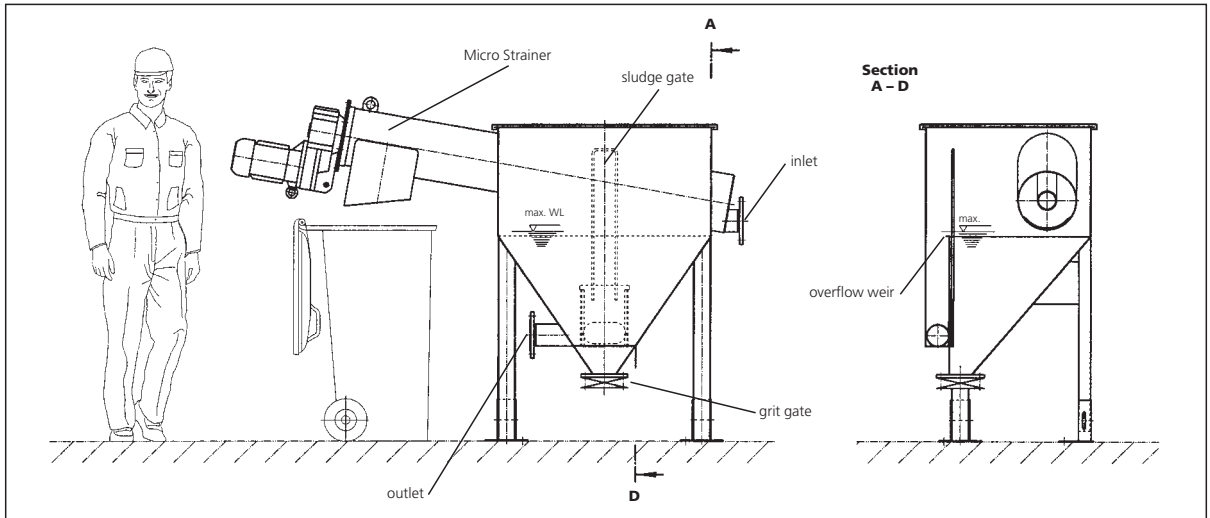

## ►► Features

The MiniCop is an inexpensive, compact and easy to install unit for complete pre-treatment of wastewater flows of up to 115,000 GPD. It is simple to operate, and requires very little maintenance.

The incoming wastewater flows through the screen basket of a Micro Strainer with 1/8" (3 mm) perforations. The retained screenings are removed with a shafted screw that is provided with a brush on its flights. They are conveyed through a dewatering zone and discharged into a screenings container.

The screened wastewater drains from the screen basket to the grit trap. Grit and heavy solids settle to the conical bottom while the wastewater overflows over a weir. From time to time, sludge is removed from the grit trap through a sludge gate, and settled grit is removed from the bottom of the cone through a gate valve and collected in a grit bucket or container. Wastewater and sludge flow to the treatment plant.

## ►► Applications

Inexpensive, complete pre-treatment unit for:

- Small wastewater treatment plants
- Decentralized wastewater treatment
- MBR systems employing flat sheet membranes, e.g. Huber VRM® membranes
- HUBER BioMem® container plants

## ►► Benefits

- Inexpensive, complete pre-treatment unit for small flows
- Compact design, small footprint, easy installation
- Easy operation and maintenance
- Long life, made of stainless steel, pickled in an acid bath

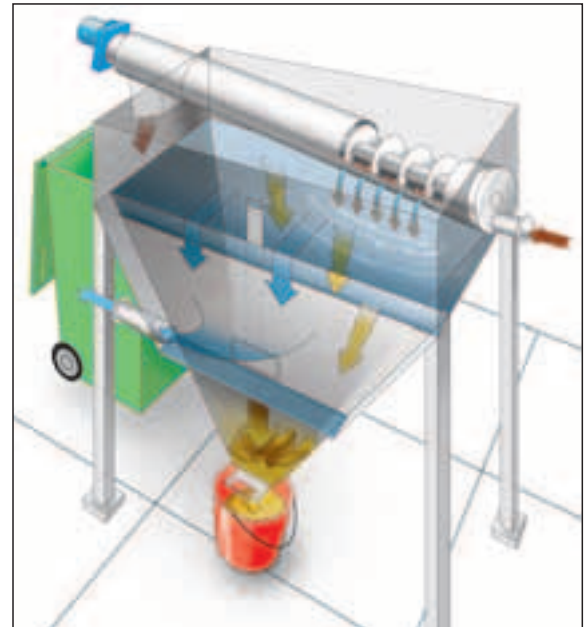

**HUBER TECHNOLOGY, Inc.**

9805 NorthCross Center Ct.  
Suite H  
Huntersville, NC 28078

Phone: (704) 949 - 1010

Fax: (704) 949 - 1020

huber@hhusa.net

<http://www.huber-technology.com>

Subject to technical modification

**ROTAMAT®**

Mini Complete Plant  
MiniCop